

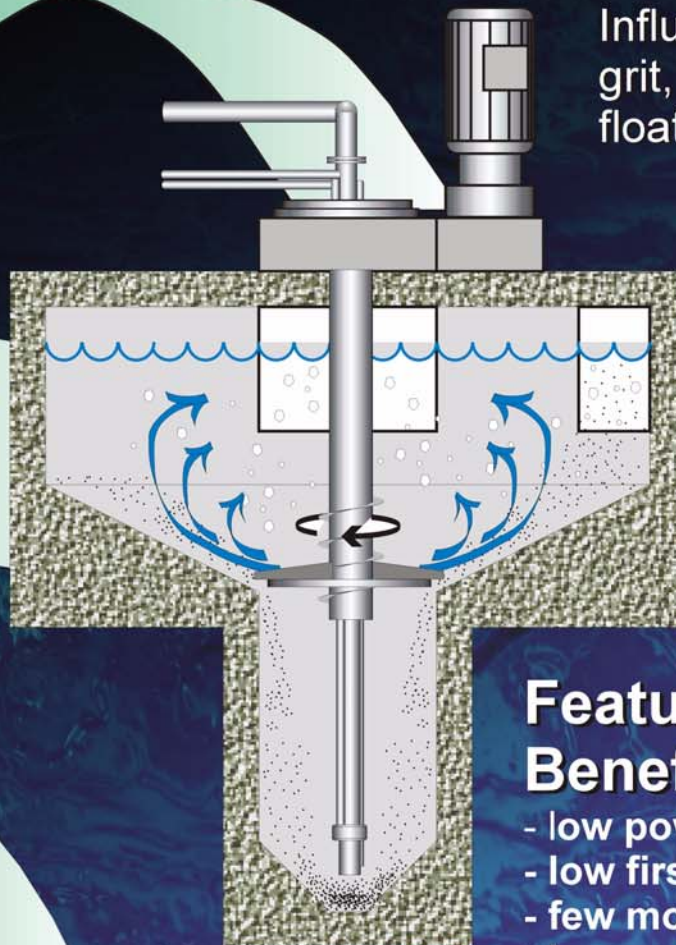

SPIRAC Vortex Grit Capture System

Grit slurry pumped to a grit classifier.



Influent stream with grit, organics and floating particulate

Outlet Stream with retained organics and floating particulate.

Features & Benefits:

- low power consumption
- low first cost
- few moving parts
- low maintenance
- simple/reliable operation

Large Capacity Range:

50 - 2000 lps



System Operation

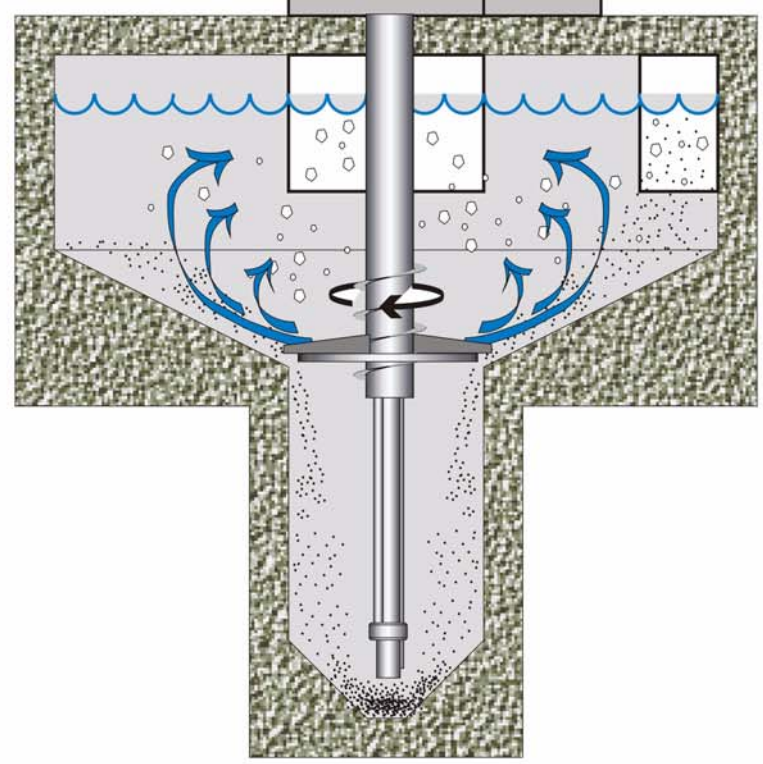

Continuous Operation:

1. Influent enters the circular settling chamber through inlet channel.
2. The stream decelerates and all particulate with a $SG > 1$ tends to settle toward the upper settling tank bottom
3. A slowly rotating impeller creates a vortex zone which acts only on the lower density particles, spiraling them upward to the chamber outlet.
4. The denser grit particles settle further into the lower grit chamber to settle on the bottom.

Cyclic Operation:

1. On a timed start, an air blower starts and injects a high velocity air stream into the Lower settling zone to fluidize the settled grit and break up any lumps.

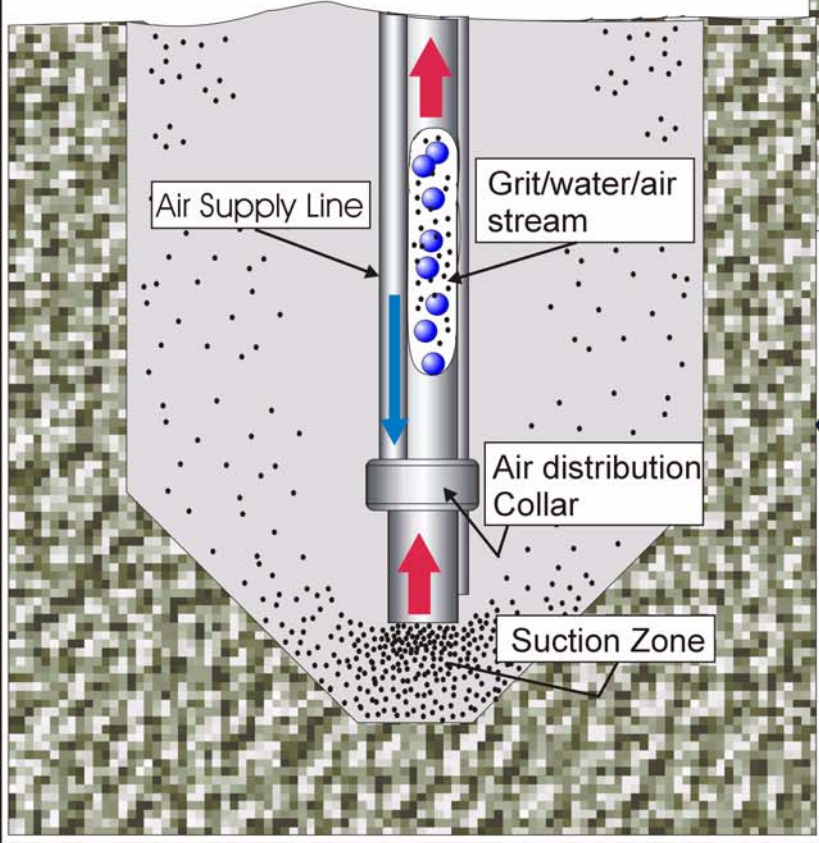
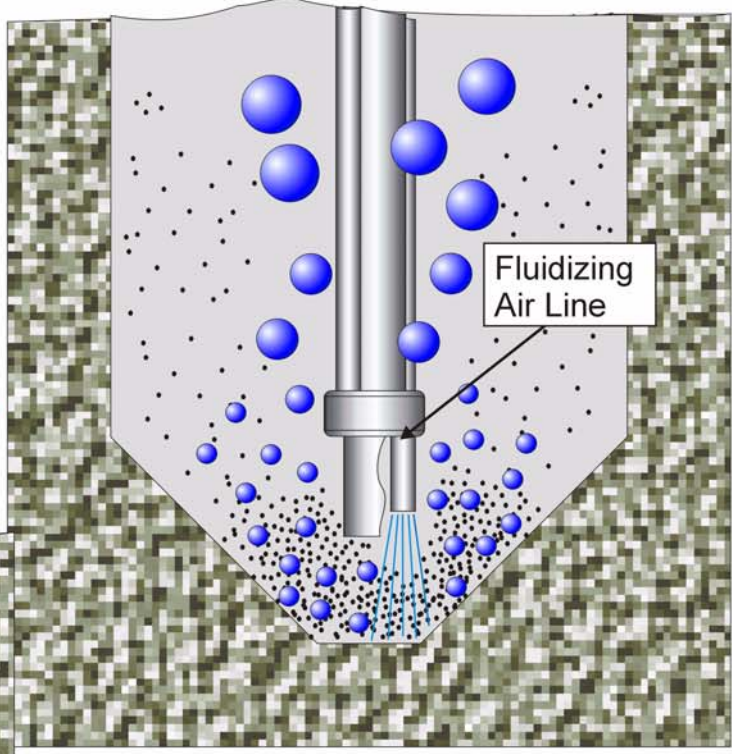

2. A three way valve diverts the air stream into a second line which feeds air into the bottom of the extraction pipe. The bubbles rise rapidly through buoyancy, inducing suction from the bottom end of the pipe. The cycle pumping cycle continues until it times out.

3. The cycle repeats every few hours, depending on the grit loading.



SPIRAC Vortex Grit System

Dimensional Data and Performance Parameters

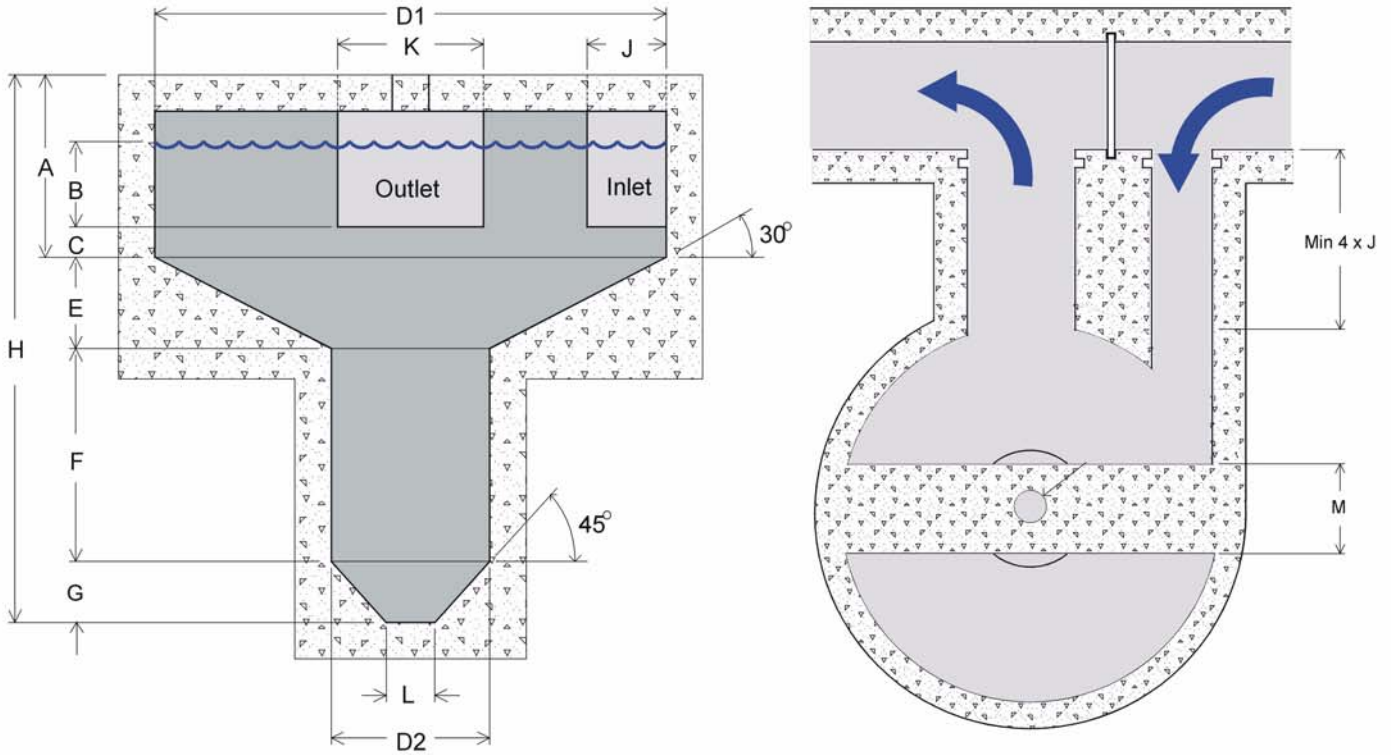

Model	Max Flowrate (lps)	Internal Diameters		Height	A	B	C	E	F	G	Inlet J	Outlet K	L	M
		D1	D2											
VG20	84	2000	1000	2800	1110	210	310	290	1050	350	310	620	300	800
VG25	193	2500	1000	2830	1000	320	170	430	1050	350	390	780	300	800
VG30	300	3000	1000	3010	1030	410	120	580	1050	350	490	970	300	800
VG35	473	3500	1500	3540	1260	470	170	580	1150	550	630	1240	400	800
VG40	628	4000	1500	4120	1400	580	390	720	1450	550	770	1550	400	800
VG45	772	4500	1500	5050	1980	600	640	870	1650	550	990	1980	400	800
VG50	968	5000	1500	5010	1800	620	600	1010	1650	550	1090	2180	400	800
VG55	1337	5500	1500	5750	2100	700	900	1150	1950	550	1200	2400	400	800
VG60	2056	6000	1500	5800	2000	760	890	1300	1950	550	1220	2400	400	800



SPIRAC Vortex Grit System

General Arrangements (Simplified) and available options

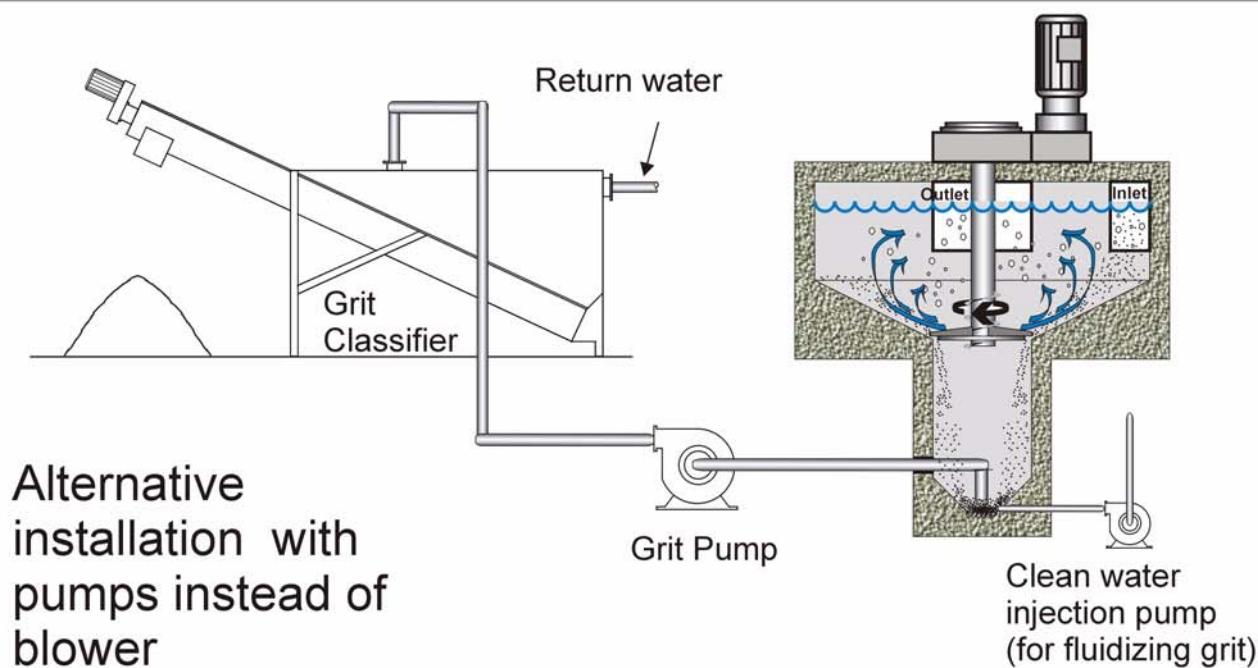
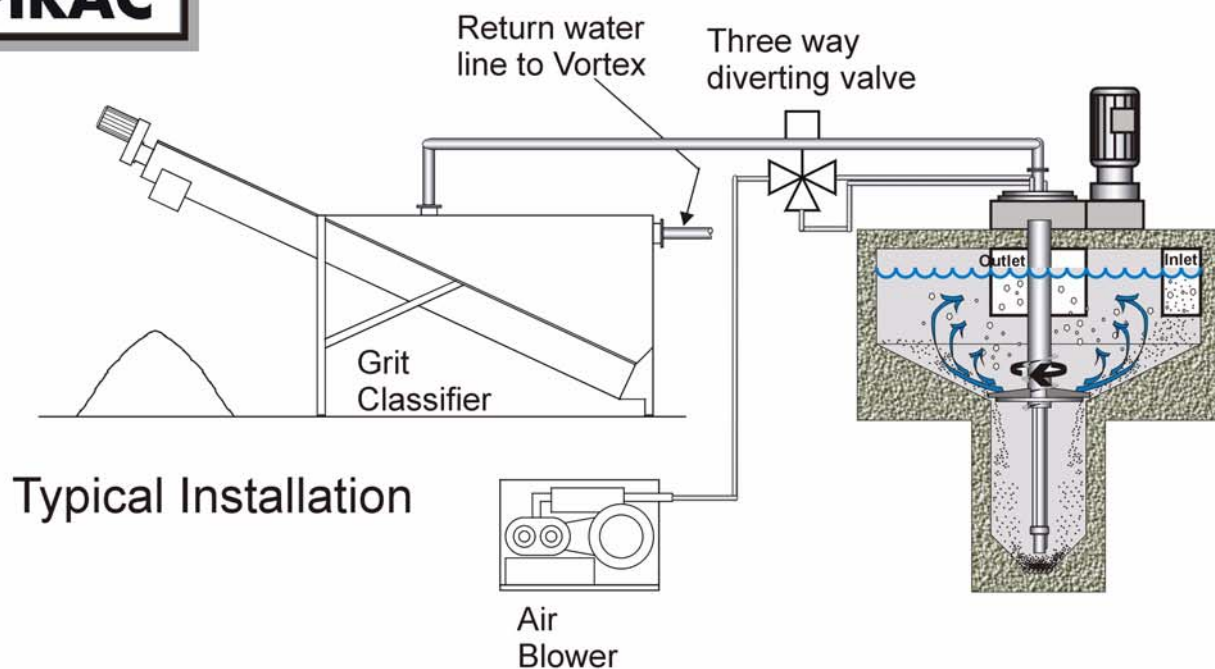

Available Options:

- stainless steel tank (in lieu of concrete) for free standing applications
- variable speed impeller drive
- adjustable pitch impeller blades
- blower acoustic enclosures
- PLC or electronic control packages