



SPIRAC®

Solid Handling Solutions

SANDSEP®

THE SANDSEP® IS A HIGH-EFFICIENCY CLASSIFIER DESIGNED TO SEPARATE GRIT AND OTHER HEAVY PARTICLES FROM PROCESS AND EFFLUENT STREAMS

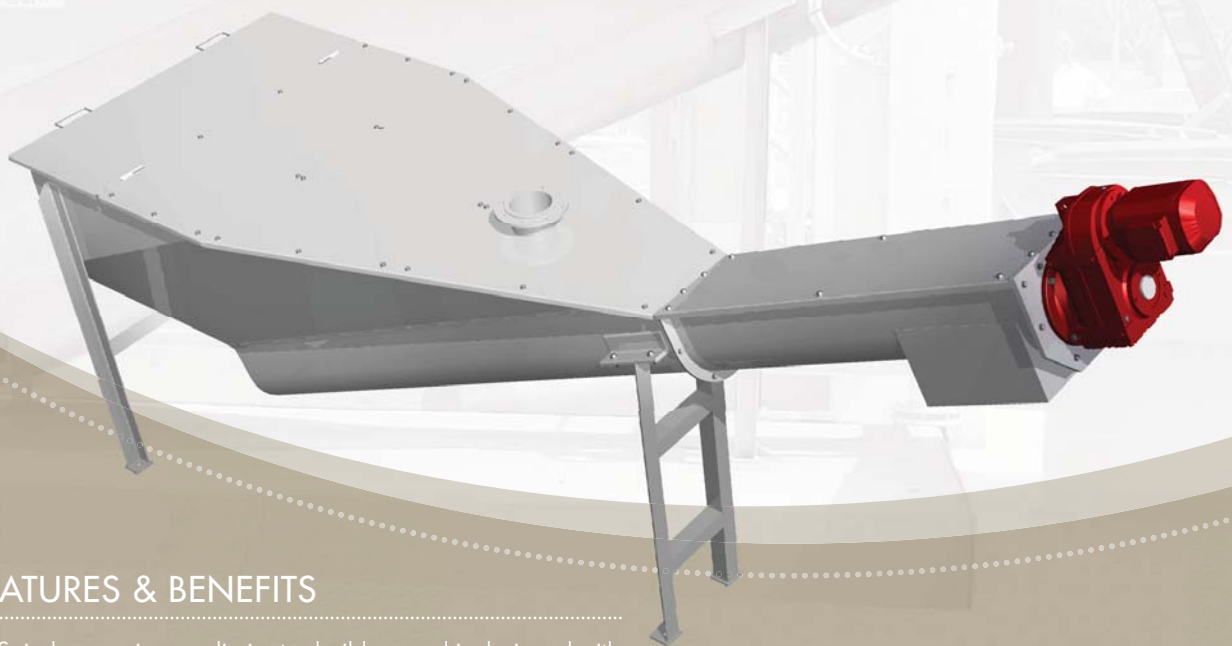

FEATURES & BENEFITS

- ▶ Spiral conveying = eliminates build up and is designed with no intermediate or end bearings under water.
- ▶ Low speed = long life-expectancy.
- ▶ Low energy consumption = cost savings.
- ▶ Compact and robust design = low maintenance.



SANDSEP® FACTS AND INFORMATION

The SANDSEP® is a highly efficient dewatering device designed to handle grit and sedimenting pollutants in sewage treatment plants.

The SANDSEP® is typically used in sewage treatment plants for grit, and in paper mills or industrial plants for sand, bark, glass and metal pollutants. There is also a special design for handling floating materials. The inlet section is designed to keep turbulence to a minimum and creates an optimum flow pattern for efficient settling. The solids settle in the bottom of the classifier which contains a spiral. The inclined spiral transports the sediment slowly (speeds are kept to around 5 RPM) to minimize turbulence to the discharge.

The bottom conveyor is derived from the SPIRAC® spiral range which offers:

- ▶ Compact dimensions with optimal dewatering/transport capacity.
- ▶ Having no exposed bearings eradicates problems normally associated with wet applications.

The SANDSEP®'s overflow weir arrangement avoids blockage from floating materials. It features minimal maintenance requirements due to:

- ▶ Its compact and robust design.
- ▶ Its direct-coupled gear-motor drive which does not use a central shaft and therefore eradicates the need for bearings and submerged seals.

STANDARD DESIGN

The SANDSEP® is equipped with a bolted lid over the tank and free length of the conveyor, and has an inspection door with easy opening over the overflow weir. The conveyor trough is equipped with wear bars. The drive unit is directly coupled to the driveshaft of the spiral.

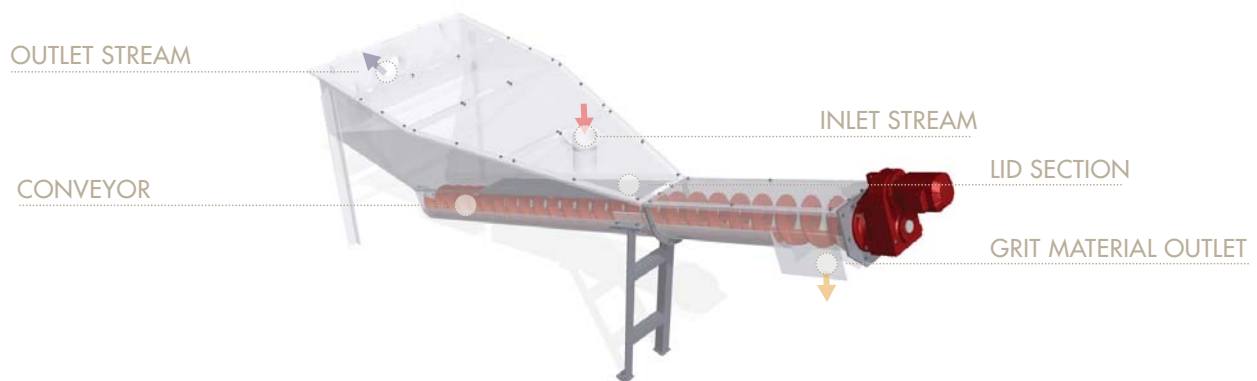

SANDSEP® TECHNICAL SPECIFICATION

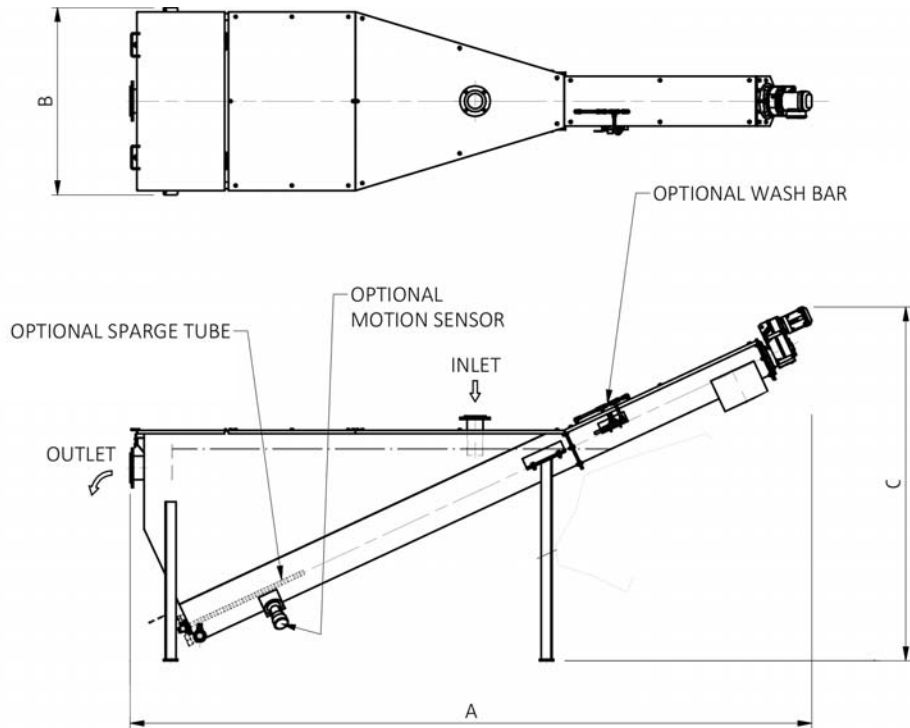

MODEL	HYDRAULIC CAPACITY (GPM)	INFLUENT INLET-CONNECTION (NB)	EFFLUENT OUTLET-CONNECTION (NB)	DISCHARGE CAPACITY AT GRIT LOADING (yd ³ /hr)	MAX. MOTOR SIZE (HP)	A (in)	B (in)	C (in)
SA200	up to 80	3	4	0.4	0.5	133"	36"	71"
SA250	80 - 190	4	6	0.7	0.5	191"	44"	99"
SA320	190 - 320	6	8	1.6	1.0	196"	59"	103"
SA355	320 - 430	8	10	2.2	1.5	258"	62"	131"
SA420	430 - 550	10	12	2.9	2.0	273"	74"	138"

Dimensions are for information only and not to be used for design. Please contact us for more details.

SANDSEP® INSTALLATIONS



ABOUT SPIRAC®

SPIRAC® is all about screening, grit and sludge handling solutions. With SPIRAC® solids handling solutions, you can have total confidence in a global leader. SPIRAC® enjoys more than 40 years of worldwide success and long-standing partnerships with customers, a prestigious status we didn't earn overnight. The SPIRAC® network of engineers is on hand to collaborate with you right from the start of your project – wherever you are located. This way we understand your requirements enabling us to deliver the right solution for you. Professional Project Managers and Design Engineers will ensure that products and systems are manufactured, installed and maintained to the most exacting standards, in compliance with local specifications and best global practice. And don't forget, full after sales support is part of SPIRAC's® outstanding service.

WE SPECIALIZE IN

SCREENINGS HANDLING

- ▶ Screens
- ▶ Screenings washing
- ▶ Dewatering & compaction
- ▶ Conveying
- ▶ Containment & transport

GRIT HANDLING

- ▶ Grit capture & separation
- ▶ Grit washing
- ▶ Conveying
- ▶ Containment & transport

SLUDGE HANDLING

- ▶ Conveying
- ▶ Storage (silos)
- ▶ Receival (bunkers & hoppers)
- ▶ Outloading (sliding-frames & live-bottoms)
- ▶ Containment & transport

PLEASE CONTACT US FOR MORE INFORMATION

AUSTRALIA
SPIRAC Pty Ltd

Western Australia (Perth)
+61 8 9434 0777

New South Wales (Sydney)
+61 2 8811 4100

Victoria (Melbourne)
+61 3 9717 1199

Queensland (Brisbane)
+61 7 3482 4230

info@spirac.com.au

NETHERLANDS
SPIRAC BV

Maarheeze
+31 (0) 495 430 203
info@spirac.nl

UNITED KINGDOM
SPIRAC Limited

Banbury
+44 (1) 295 270 335
conveyors@spirac.co.uk

SWEDEN
SPIRAC AB

Limhamn
+46 40 36 22 00
info@spirac.se

USA
SPIRAC (USA) Inc

Newnan GA
+1 770 632 9833
sales@spirac.com

