

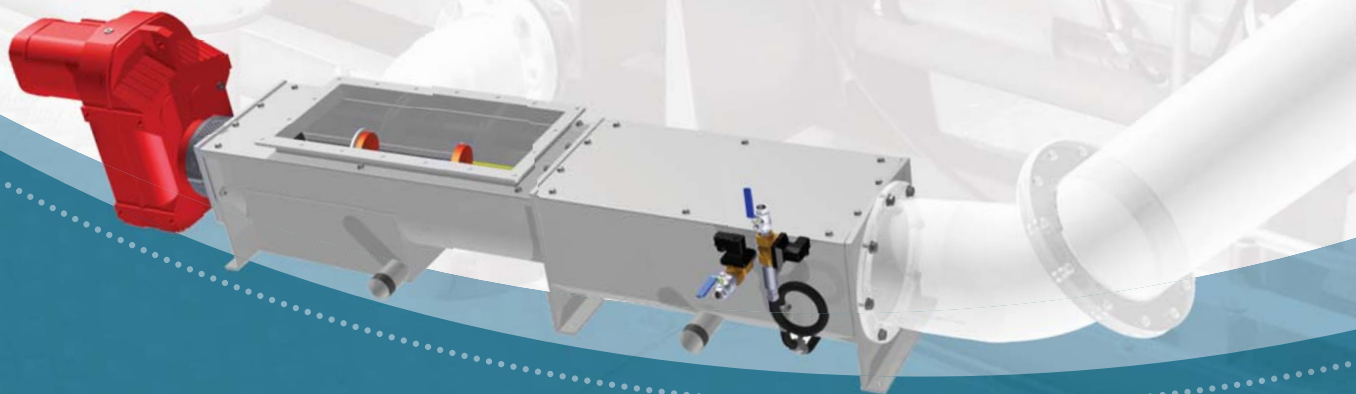

**SPIRAC**<sup>®</sup>  
Solid Handling Solutions

## **SPIROWASH**<sup>®</sup>

**SEWAGE SCREENINGS, WASHING AND DEWATERING**



### **FEATURES & BENEFITS**

- ▶ Low power and washwater usage.
- ▶ Tolerant to high grit and fat loadings = high reliability during operation.
- ▶ Simple automatic control for great flexibility.
- ▶ Degree of wash out is approximately 80-90%.
- ▶ Dewatered final product – up to 45% DS.
- ▶ Volume reduction - typical output approximately 55-60%.
- ▶ Weight reduction - typical output approximately 65%.

SPIRAC's units are designed to offer simple yet effective, low-maintenance and high-volume treatment of sewage screenings. Efficient washing is offered with low residual organics contents, whilst consuming low volumes of washwater.

SPIROWASH® is designed to convey, wash, dewater and compact captured screenings from the inlet works of wastewater treatment plants.

As an integral part of the inlet works process equipment, the SPIROWASH® can receive captured screenings material from a variety of mechanical screens including step, band, and coarse-raked screens. The screenings can be either discharged from the screen source directly into the inlet zone, or they can be launder-sludge fed. The rotating shafted screw conveys the material forward into the wash zone whilst water drains off from the screenings into the drain box through the screen. In the wash zone, pressurised water is sprayed onto the screenings, removing organics as the screw flights rotate in an intermittent forward and reverse movement.

Excess water is extracted in the compression and dewatering zone. As the press tube fills with

compacted and dewatered screenings, the increased back pressure improves the dewatering process. The discharged product from the end of the presstube typically falls out into a waste bin in the form of compacted plugs.

As the length of the plug material increases, the screw pushes the plug up through the discharge tube compacting it in the process.

The raw screenings throughput capacity of the Screening Washer is up to 8m<sup>3</sup>/hr in the standard range. SPIRAC Screening Washers come in slightly different types and sizes. The overall layout can also be customized to suit the individual specific project requirements. The next pages have details on the different types and sizes but please feel free to contact SPIRAC or any of our representatives to discuss your particular project requirements.

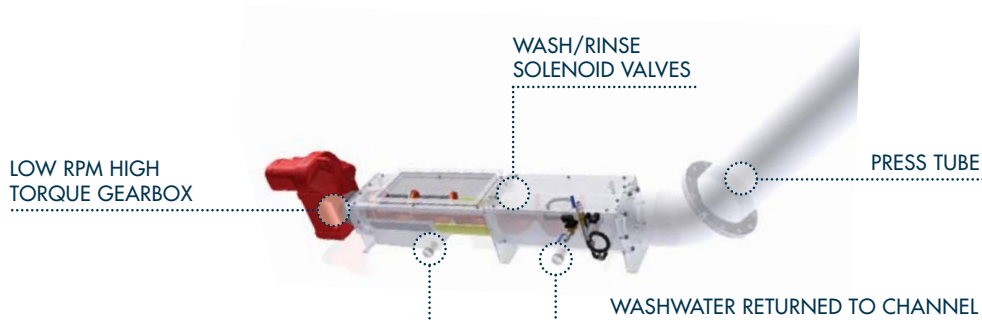

## STANDARD TYPES AND SIZES

Currently there are three main SPIROWASH® types.

DESCRIPTION	MODEL SIZE			
SPIROWASH® Standard / Compact	SW-160	SW-215	SW-280	SW-365
SPIROWASH® High Flow	SW-Q160	SW-Q215	SW-Q280	SW-Q365
SPIROWASH® High Impact	SW-H160	SW-H215	SW-H280	SW-H365

## SPIROWASH® CAPACITY AND WATER REQUIREMENTS

MODEL	SPIRAL DIAMETER (mm)	CAPACITY RANGE (m³/h)	WASH WATER REQUIREMENTS AT 3-6 BAR (L/sec)	FLUSH WATER REQUIREMENTS AT 3-6 BAR (L/sec)
SW-160, SW-Q160, SW-H160	160	Up to 1.0	1.2	0.5
SW-215, SW-Q215, SW-H215	215	1.0 to 2.5	1.2	0.5
SW-280, SW-Q280, SW-H280	280	2.5 to 4.5	1.4	0.7
SW-365, SW-Q365, SW-H365	365	4.5 to 8.0	1.4	0.7

Notes: 1) Please contact us for technical specifications on larger units.

2) Dimensions are for information only and not to be used for design. Please contact us for more details.

## SPIROWASH® COMPACT

This is one of the more common and most versatile washing and compaction units, which is best suited for screenings that have been pre-drained from

the excess water in launder-sludge applications. Its robust and reliable design allows for minimum maintenance over the life of the machine.

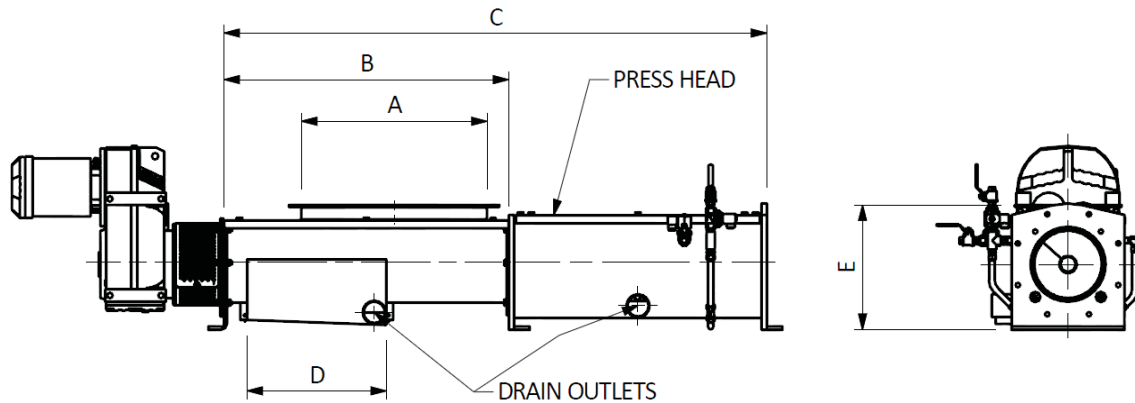

MODEL	INLET WIDTH (mm)	A (mm)	B (mm)	C (mm)	D (mm)	E (mm)	Weight (kg)	DRIVE UNIT (kW/RPM)
SW-160	200	300 - 1200	A + 320	A + 1054	350	380	262 - 300	1.5 / 10
SW-215	250	300 - 1600	A + 320	A + 1154	450	400	397 - 471	3.0 / 11
SW-280	320	400 to 2000	A + 320	A + 1254	550	489	668 - 791	4.0 / 10
SW-365	420	500 to 1600	A + 320	A + 1454	560	599	1120 - 1260	7.5 / 10

Notes: 1) Dimensions are for information only and not to be used for design. Please contact us for more details.

2) The inlet arrangement shown is a common single-flanged type. Custom arrangements are available eg. flared, multiple, extended.

## SPIROWASH® HIGH FLOW

Sharing similar design features and characteristics to the SPIROWASH COMPACT, this unit has an extended drain box in the inlet zone to accommodate screenings received from launder-slucie applications.

The extended drain section allows excess free liquid to be efficiently pre-drained prior to the final washing and compaction cycle.

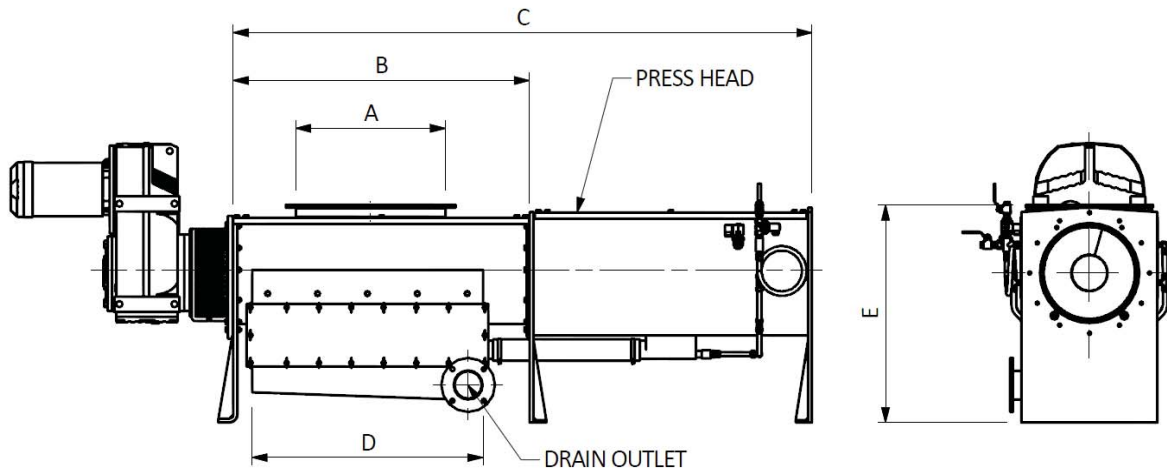

MODEL	INLET WIDTH (mm)	A (mm)	B (mm)	C (mm)	D (mm)	E (mm)	Weight (kg)	DRIVE UNIT (kW/RPM)
SW-Q-160	200	300 - 1200	A + 586	A + 1320	A + 326	605	319 - 384	1.5 / 10
SW-Q-215	250	300 - 1600	A + 586	A + 1420	A + 326	703	483 - 600	3.0 / 11
SW-Q-280	320	400 - 2000	A + 586	A + 1520	A + 326	737	786 - 962	4.0 / 10
SW-Q-365	420	500 - 1600	A + 586	A + 1720	A + 326	867	1258 - 1438	7.5 / 10

Notes: 1) Dimensions are for information only and not to be used for design. Please contact us for more details.

2) The inlet arrangement shown is a common single flanged type. Custom arrangements are available eg. flared, multiple, extended.



SPIROWASH®  
HIGH IMPACT

## SPIROWASH® HIGH IMPACT

When removing high levels of organic materials from screenings is the objective, our SPIROWASH® HIGH IMPACT is the most appropriate choice. An important design feature of this unit is the addition

of a wash-box (incorporating our unique high-speed non-rag-balling impeller design), which is able to dislodge as much as 95% of organic material from the final discharged product.

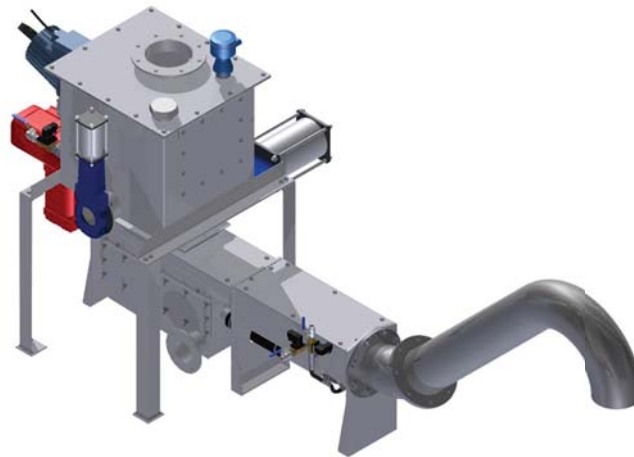

## CONSTRUCTION

The main standard material of screenings washer construction is as follows:

Trough and press tube:	316SS
Spiral:	Shafted HTMAS fitted with spirobrush over the entire screen length
Screen:	316SS with 3mm round perforations
Liners:	Duraflo SPX®
Press Head cover:	Bolted cover.



*SPIROWASH® Duplex: all models are available as a duplex configuration that has the effect of doubling the quoted capacity.*



*Simple design with one moving part (double-flared inlet section shown).*



SPIROWASH®  
INSTALLATION SAMPLES



**SPIRAC**  
WWW.SPIRAC.COM

**AUSTRALIA**  
**SPIRAC Pty Ltd**

Western Australia (Perth)  
+61 8 9434 0777

New South Wales (Sydney)  
+61 2 8811 4100

Victoria (Melbourne)  
+61 3 9717 1199

Queensland (Brisbane)  
+61 7 3482 4230

info@spirac.com.au

**NETHERLANDS**  
**SPIRAC BV**

Maarheeze  
+31 (0) 495 430 203  
info@spirac.nl

**SWEDEN**  
**SPIRAC AB**

Limhamn  
+46 40 36 22 00  
info@spirac.se

**UNITED KINGDOM**  
**SPIRAC Limited**

Banbury  
+44 (1) 295 270 335  
conveyors@spirac.co.uk

**USA**  
**SPIRAC (USA) Inc**

Newnan GA  
+1 770 632 9833  
sales@spirac.com