

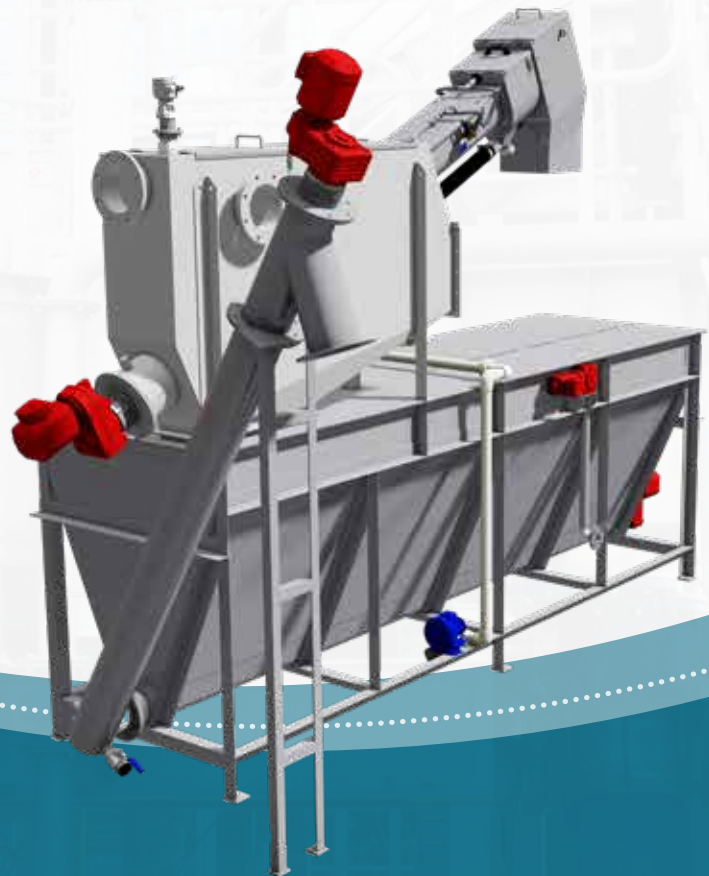

SPIRAC[®]
Solid Handling Solutions

COMBIGUARD[®]

PREFABRICATED INLET WORKS
SOLUTION FOR THE REMOVAL
OF SCREENINGS AND GRIT



FEATURES AND BENEFITS

- ▶ A complete screening, grit capture and washing system.
- ▶ Designs and layout able to be customised to suit client-specific requirements.
- ▶ Space-saving solution for facilities requiring low equipment footprint.
- ▶ Lower capital cost, power consumption and wash-water usage.
- ▶ A prefabricated solution that requires greatly reduced installation time on site.
- ▶ SPIRAC technology with few moving parts, meaning lower maintenance and down time.
- ▶ Simple and reliable operation due to low head loss.
- ▶ Effective operation across a wide flow.

COMBIGUARD® INLET WORKS PACKAGES

Bringing together a number of SPIRAC's most effective product solutions, the COMBIGUARD® has been developed to meet the requirements of small- to large-size municipal communities, for the removal of screenings and grit.

SPIRAC offers a range of individual equipment solutions for wastewater treatment plants. Such a diverse product range coupled with a high level of knowledge and expertise makes our sales, design and project management teams able to offer packaged inlet works solutions for the smallest to largest WWTP.

The COMBIGUARD® unit combines the features of:

SPIROGUARD Compact Cleaner (CC)

This machine combines screening, conveying, dewatering and removal of solids from effluent and process streams in one compact machine. The screen ideally suited as a tanker reception facilitator screening separation unit. SPIROGUARD® is robust, easy to install and, with only one moving part, virtually maintenance free. Slow speed combined with automatic intermittent operation ensures a

reliable and efficient system. The SPIROGUARD® CC Screen is designed as a standalone unit for pump-fed or tanker gravity flow applications.

SANDSEP® Classifier

The SANDSEP® is a highly efficient unit designed to separate grit and other pollutants from process and effluent streams. The design of the inlet section reduces turbulence to a minimum and creates an optimum flow pattern for efficient settling. The solids settle in the bottom of the classifier, which contains a spiral. The spiral transports the sediment slowly (speeds are kept to around 5 RPM to minimise turbulence) to an inclined or vertical conveyor, which then discharges the grit.

COMBIGUARD® is your solution when you need to create a complete end-to-end wastewater pre-treatment plant, that covers all of the applications required for municipal facilities. When brought together with screenings washing, dewatering and flotation, a complete inlet works system can be created.



COMBIGUARD® Type 1 including press head

Type 1:

SPIROGUARD® with or without Manual Bar Screen by-pass and a SAL (Rectangular tank with horizontal & incline conveyors). The following options are available:

- ▶ Aeration diffuser system for retention of organics during low or no flow conditions
- ▶ Fat, oil, grease (FOG) skimmer
- ▶ Press head for cost effective dewatering and compaction of screenings
- ▶ Longopac bagging systems for complete containment of screenings and grit

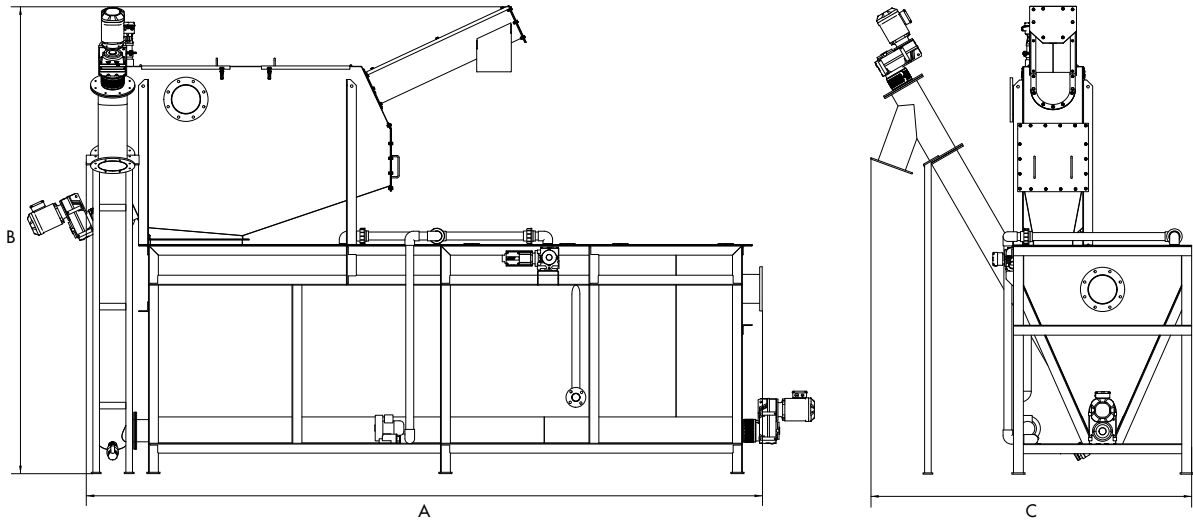

| Model | A (mm) | B (mm) | C (mm) | Nominal Capacity (lps) |
|------------|-----------|-----------|-----------|---------------------------|
| CG-200-040 | 3660 | 3405 | 2380 | 40 |
| CG-250-060 | 5160 | 3545 | 2370 | 60 |
| CG-250-080 | 6660 | 3545 | 2370 | 80 |
| CG-300-100 | 8125 | 3730 | 2370 | 100 |
| CG-350-120 | 9625 | 3770 | 2370 | 120 |
| CG-400-140 | 11125 | 4020 | 2370 | 140 |
| CG-400-160 | 12625 | 4020 | 2370 | 160 |



*COMBIGUARD® Type2 including SPIROGUARD®,
Grit Vortex and SANDWASH™*

Type 2:

We offer a wide range of equipment combinations, and screens enabling this type of COMBIGUARD® to be adapted to any requested flow requirement.



SPIRAC[®]
WWW.SPIRAC.COM

AUSTRALIA
SPIRAC Pty Ltd

Western Australia (Perth)
+61 8 9434 0777

New South Wales (Sydney)
+61 2 8811 4100

Victoria (Melbourne)
+61 3 9717 1199

Queensland (Brisbane)
+61 7 3482 4230

info@spirac.com.au

NETHERLANDS
SPIRAC BV

Maarheeze
+31 (0) 495 430 203
info@spirac.nl

SWEDEN
SPIRAC AB

Limhamn
+46 40 36 22 00
info@spirac.se

UNITED KINGDOM
SPIRAC Limited

Banbury
+44 (1) 295 270 335
conveyors@spirac.co.uk

USA
SPIRAC (USA) Inc

Newnan GA
+1 770 632 9833
sales@spirac.com