

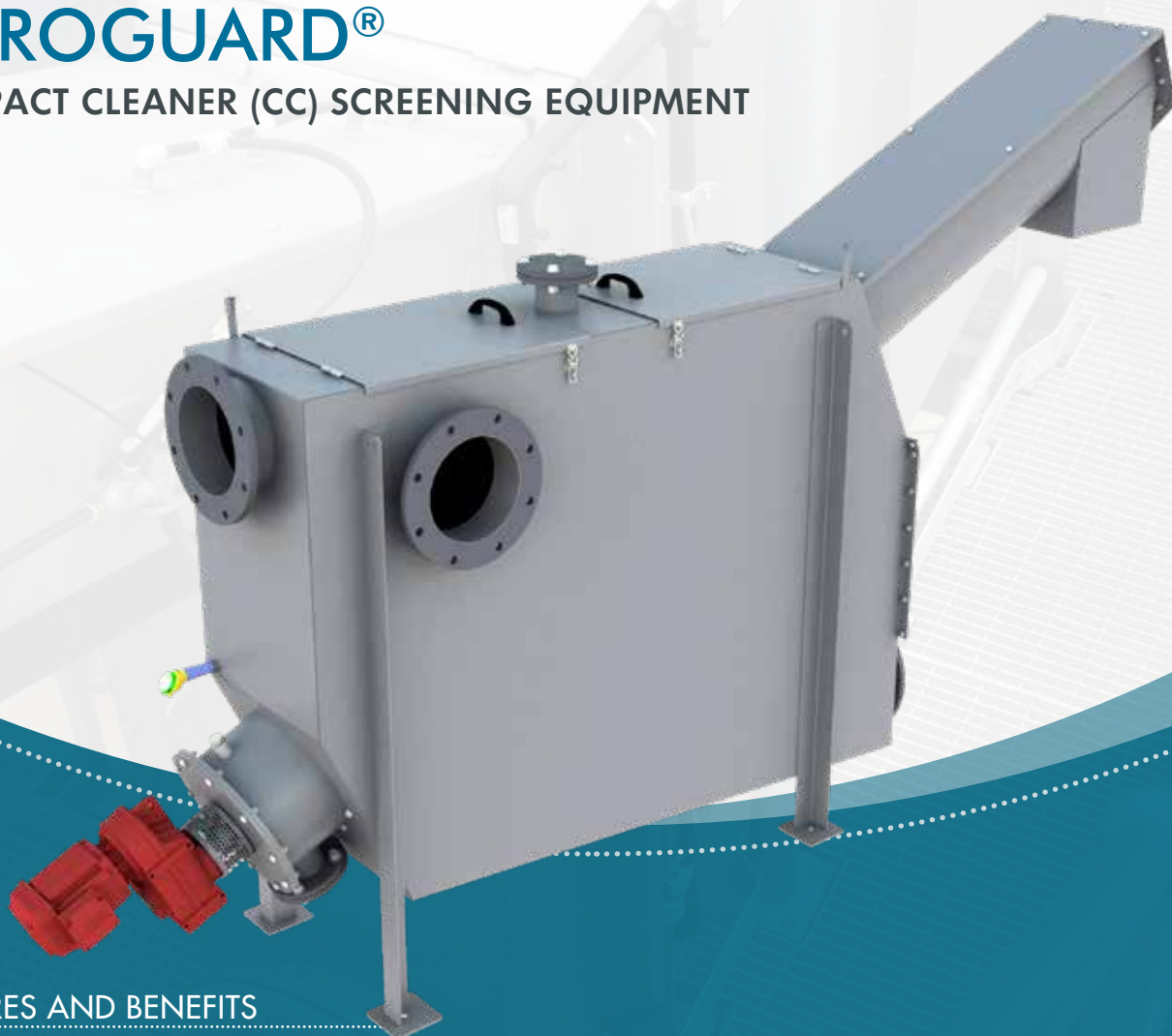

SPIRAC[®]
Solid Handling Solutions

SPIROGUARD[®]

COMPACT CLEANER (CC) SCREENING EQUIPMENT



FEATURES AND BENEFITS

- ▶ Low operating speed = low maintenance costs.
- ▶ Low energy consumption = cost savings.
- ▶ Compact, robust design = machine is virtually maintenance free.
- ▶ Hinged covers = easy inspection of spiral.
- ▶ Shaftless Spiral have no intermediate or end bearings = no material build up or blockage will ever occur.

SPIRAC's screening and classifying equipment brings together our unique shaftless screw technology and superior screen design to create systemised streamlined and robust solutions. In one compact machine, SPIROGUARD® CC combines screening, conveying, dewatering and solids removal from effluent and process streams.

The unit is robust, easy to install and, with only one moving part, virtually maintenance free. Slow speed combined with automatic intermittent operation ensures

a reliable and efficient system. Currently, SPIRAC® offers the legendary SPIROGUARD® compact cleaner (CC) with optional presshead and wash zone.

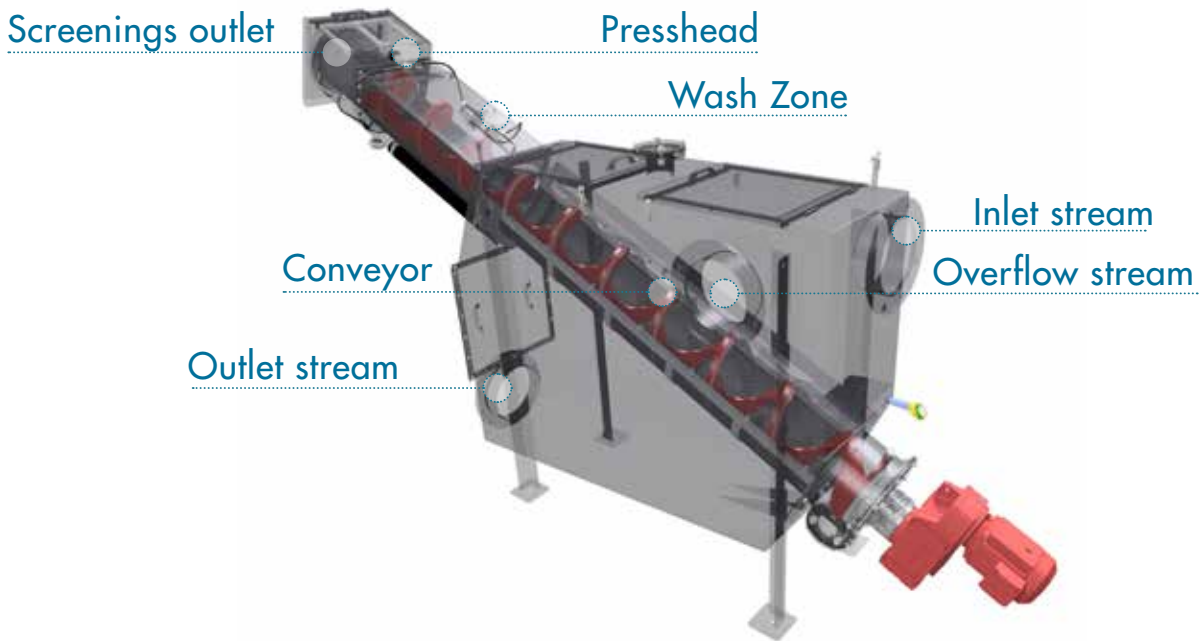

SPIROGUARD® CC SCREEN

The SPIROGUARD® CC Screen is designed as a standalone unit for pump-fed applications and is available with or without a press head. Ideally suited as a tanker reception facilitator screening separation unit, it is robust and easy to install. With only one moving part, this unit is virtually maintenance free. Slow-speed combined with automatic intermittent operation ensures a reliable and efficient system.

Options:

- ▶ Screenings washings
- ▶ Conveying
- ▶ Dewatering
- ▶ Compacting

Technical data:

- ▶ Capacity of wet screenings up to 4yd³/h
- ▶ Weight reduction up to 80%
- ▶ Volume reduction up to 60%
- ▶ Dewatering efficiency 30-50%

SPIROGUARD® CC SCREEN

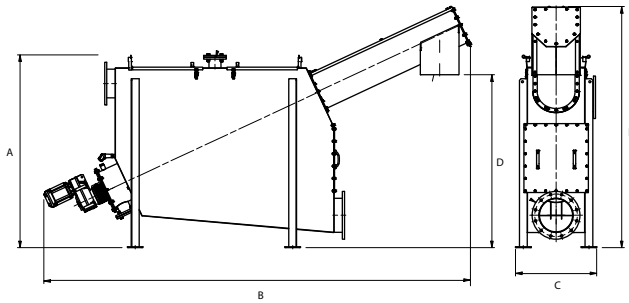

CC Unit

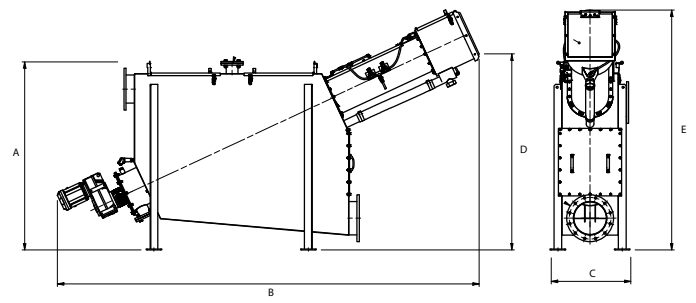

CCP Unit

Model	A (in)	B (in)	C (in)	D (in)	E (in)	Hydraulic Capacities (gpm)						
						Wedgewire Screens			Perforated Screens			
						1mm	2mm	3mm	2mm	3mm	5mm	6mm
CC200/ CC200P	63"	138"/146"	25"	56"/66"	73"/76"	761	1078	1331	761	697	618	919
CC250/ CC250P	69"	145"/ 149"	27"	62"/70"	82"/83"	1094	1331	1331	1094	983	872	1316
CC300/ CC300P	68"	159"/164"	29"	63"/72"	87"/88"	1395	1965	2536	1395	1252	1125	1680
CC350/ CC350P	73"	160"/162"	31"	65"/75"	90"/92"	1553	2171	3107	1553	1395	1236	1854
CC400/ CC400P	84"	179"/186"	32"	73"/86"	102"/104"	2298	3218	4042	2298	2061	1839	2758
CC500/ CC500P	84"	199"/191"	36"	77"/84"	111"/106"	2726	3820	4929	2726	2457	2187	3281
CC600*	92"	202"	40"	78"	119"	3281	4581	4929	3281	2948	2615	3931

- Notes:
- 1) Dimensions are for information only and not to be used for design. Please contact us for more details.
 - 2) SPIROGUARD® CC units are available with or without pressheads (P).
 - 3) Available Range 1,2,3mm wedgewire and 2,3,5,6mm perforated plates.

* Units isn't available with a presshead.



SPIROGUARD® CC300P



SPIROGUARD® CC600P



SPIROGUARD® Conveyor



SPIROGUARD® CC200P

PLEASE CONTACT US FOR MORE INFORMATION

SPIRAC (USA) INC.

Postal Address:
75 Jackson Street Suite
300 Newnan Georgia 30263

Phone. +1 (770) 632 9833
Fax. +1 (770) 632 9838
E-mail. sales@spirac.com

WWW.SPIRAC.COM