

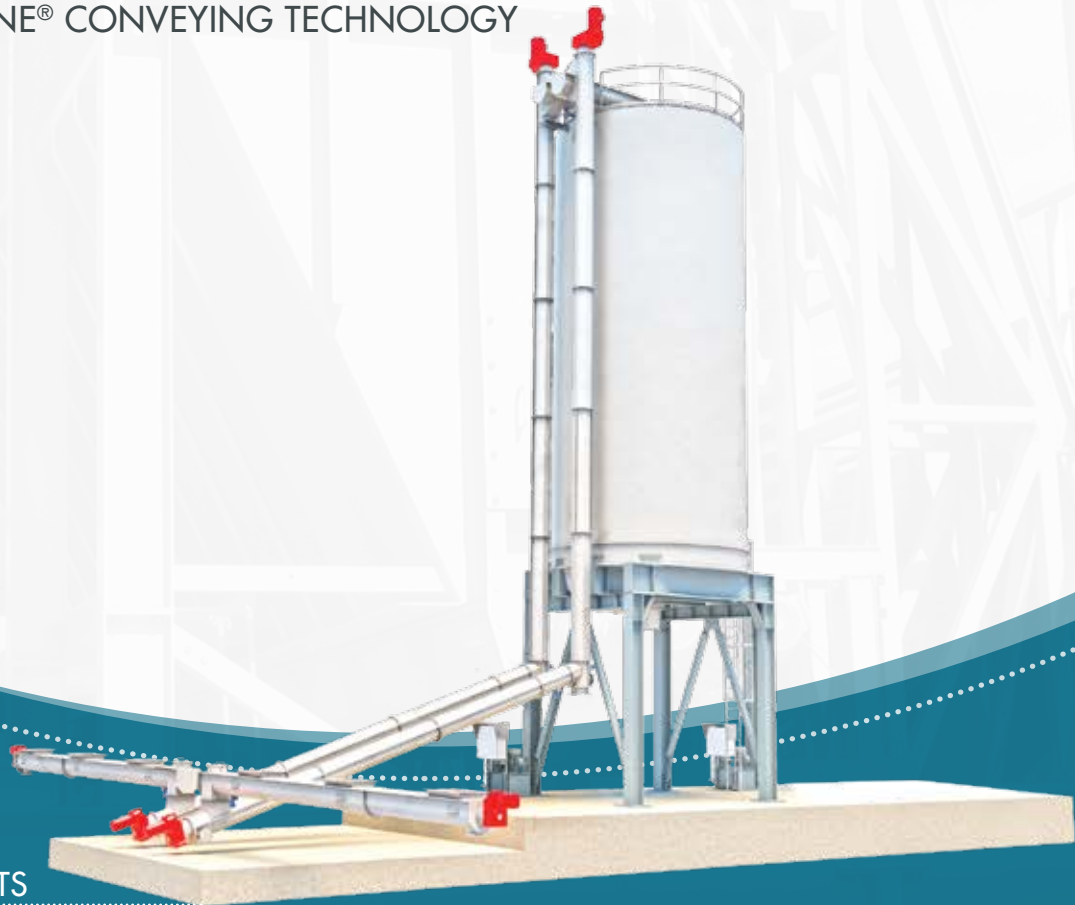

SPIRAC[®]
Solid Handling Solutions

SHAFTLESS SPIRAL CONVEYORS

SPIROLIFT[®] & SPIROLINE[®] CONVEYING TECHNOLOGY



FEATURES AND BENEFITS

- ▶ Low RPM for long life expectancy from minimal wear of components = virtually maintenance free.
- ▶ Low power usage = energy savings.
- ▶ Less wear = less down time.
- ▶ Space saving.
- ▶ Handling of large objects, up to trough diameter.
- ▶ Fully sealed lids, gasketed joins for tight odor and mess containment.

SPIRAC provides customized conveying equipment that meets the solids material handling requirements of industries all over the world. Based on our 40 years of experience in innovative design and provision of leading-edge conveying technology, SPIRAC is able to adapt easily to changing industry needs.

SHAFTLESS SPIRAL

The shaftless spiral allows higher filling rates and lower RPMs resulting in less wear and consequently less maintenance and down time. Although the spirals can be made out of many different materials, the primary material is a special steel from Sweden which has mechanical properties that give the SPIRAC spiral a very high tensile strength. SPIRAC shaftless spiral conveyors are designed for the transport of otherwise difficult to handle materials, such as municipal dewatered sludge, wastewater screenings, grit, industrial sludges and other sticky, viscous, stringy materials.

NO INTERMEDIATE OR END BEARINGS

Not having intermediate and end bearings allows a comparative reduction in major maintenance work. It also allows efficient and direct transfer – horizontal, inclined or vertical – into another conveyor.

LINERS

SPIRAC's proprietary liner, DURAFLO SPX[®], is designed specifically to ensure long life. The DURAFLO SPX[®] liner has a built-in wear indicator with a snap-in, snap-out feature enabling easy replacement.



TOTALLY ENCLOSED TROUGHS

SPIRAC conveyors are totally enclosed. There is no spillage of the material being conveyed and odours are completely contained.

DIRECT DRIVE

SPIRAC's direct-drive design allows a clean and efficient transmission without the maintenance required by belt and chain drives.

SPIROLINE[®] (U-TROUGH)

For horizontal or inclines up to 30 degrees:

- ▶ Fully enclosed with bolted or quick release lids
- ▶ Inspection ports
- ▶ 304 & 316SS, Duplex SS, mild steel.



SPIROLIFT[®] (OCTAGONAL TROUGH)

For steeper inclines or vertical transport:

- ▶ 304 & 316SS, Duplex SS, mild steel.

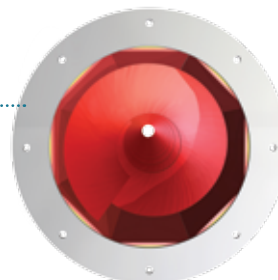

HORIZONTAL CONVEYING

SPIROLINE® (U-trough) is used for horizontal conveying of screenings, grit and sludge.

Features and benefits:

- ▶ Intended for the transport of difficult materials – suitable for a wide range of moisture contents and viscosities. High torque gearboxes and heavy duty spirals will clear materials in the most difficult conditions.
- ▶ Complex geometries and limited space easily satisfied.
- ▶ Totally enclosed troughs for odour and mess containment.
- ▶ Very high load/torque capability, can run up to 100% full, utilizing almost full cross section of trough, no restrictions to impede material flow.
- ▶ Long continuous runs on a single gearbox (up to 50m).
- ▶ Forgiving operation allows for wide capacity range.
- ▶ Axial connections, ie straight into the side of another conveyor are common, even at oblique angles.
- ▶ Sacrificial liners are designed to be easily and inexpensively replaced.
- ▶ Custom designed to match field equipment.



Long continuous sludge run



Truck unloading system

VERTICAL CONVEYING

SPIROLIFT® uses an octagonal (OK) trough that is specially designed to achieve vertical conveying of dewatered sludge and other difficult to transport materials. Breaks in the liner provide resistance points which help to prevent slippery materials forming a rotating plug, thereby encouraging the material to move vertically with the spiral face.

Features and benefits:

- ▶ Must be force fed from a horizontal or inclined conveyor.
- ▶ Can manage a wide range of sludges, 18-30% DS.
- ▶ Up to 50m³/hr (single).
- ▶ Negligible liner wear, as spiral not riding on the liner.
- ▶ Up to 13m (40ft) lift per stage, up to 3 stages.
- ▶ Typically feed into horizontal conveyors.
- ▶ Typically in pulling arrangement for sludge.
- ▶ Typically in pushing arrangement for screenings.
- ▶ Higher RPM, typically 2x horizontal feed conveyor RPM.



Typical two stage vertical lift sludge conveyors feeding a storage silo

INCLINED CONVEYING

SPIROLINE® (U-trough) and SPIROLIFT® (OK-trough) are both suitable for material transport up an incline. These can be hopper fed up to approximately 45 degrees, or force fed at steeper inclines.

Features and benefits:

- ▶ Typically SPIROLINE® (U-trough) arrangement up to 30 degrees, depending on material.
- ▶ SPIROLIFT® (OK-trough) 35-90 degrees.
- ▶ Can manage a wide range of sludges, 18-30% DS.
- ▶ High capacity, up to 90m³/hr.
- ▶ Suitable for screenings, sludge or grit (max 25 degrees).
- ▶ Hopper fed up to 45 degrees.
- ▶ Suitable for pushing or pulling drives.



1. High capacity sludge outloading system 90m³/hr.
2. 72 degree and 40 degree inclined OK-trough conveyors (sludge).



AERATED GRIT CHAMBERS

Features and benefits:

- ▶ Up to 50m in length to suit very high capacity grit settling tanks.
- ▶ Cast-in-place SS-troughs with simple installation and long life-expectancy.
- ▶ Low RPM (4-6) provides low turbulence and high torque.
- ▶ Duraflo Type SPX® (UHMWPE), moulded urethane, or wearbar type liners.
- ▶ Anti-lift bars common.
- ▶ For discharge into sump chamber and removal by grit pump.
- ▶ Standard bellhousing to provide shafted seal up to 8m of water head.

LIVE-BOTTOM/HOPPER OUTLOADING MULTI-SPIRAL SYSTEMS

SPIRAC live-bottom bin outloading systems suit a wide range of sludges and difficult to handle materials. Large diameter and pitch shaftless spirals ensure non-bridging arch free silo or bin discharge. Features axial or bottom discharge from multiple points for high speed truck outloading or low speed transfer to downstream processors such as driers and incinerators.



SLEWING CONVEYORS

Slewing conveyors are able to revolve around the inlet point, thereby allowing discharge into multiple bins or distribution of the load into a single bin, truck or storage bunker. Motorized, automated drive wheels and level sensors may be used to automatically rotate the conveyor in response to the mound level under the discharge. Bearings can be a pedestal type for floor mounting or an open-centred slewing type for suspension through a floor under a centrifuge.



BIN FILL AUTOMATION SYSTEMS

The simplest possible method is used – multiple outlets block in sequence to send material on to the next discharge point.

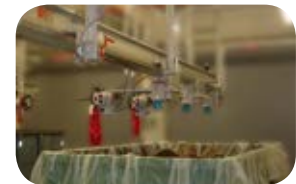

INDUSTRIAL APPLICATIONS

SPIRAC shaftless spiral conveyors also suit a wide range of industrial applications for handling sticky, difficult to transport products. Spirals can be made in multiple “laminations” to produce extremely high torque capabilities. Speciality coatings are available to reduce adherence of product to the spiral and trough components.

ACCESSORIES AND OTHER FEATURES

- ▶ Supports
- ▶ Electronic shear pins
- ▶ Automatic controls
- ▶ Motion sensors
- ▶ Limit switches
- ▶ Knife gates



Direct drive high torque gearbox



Discharge slide gates can be manual, electric or pneumatic



Perforated drain section with brush

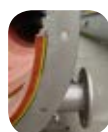

Open drain connections



Solids diverter gates



Inspection hatches

DIMENSIONS SPIROLIFT® (OK-TROUGH)

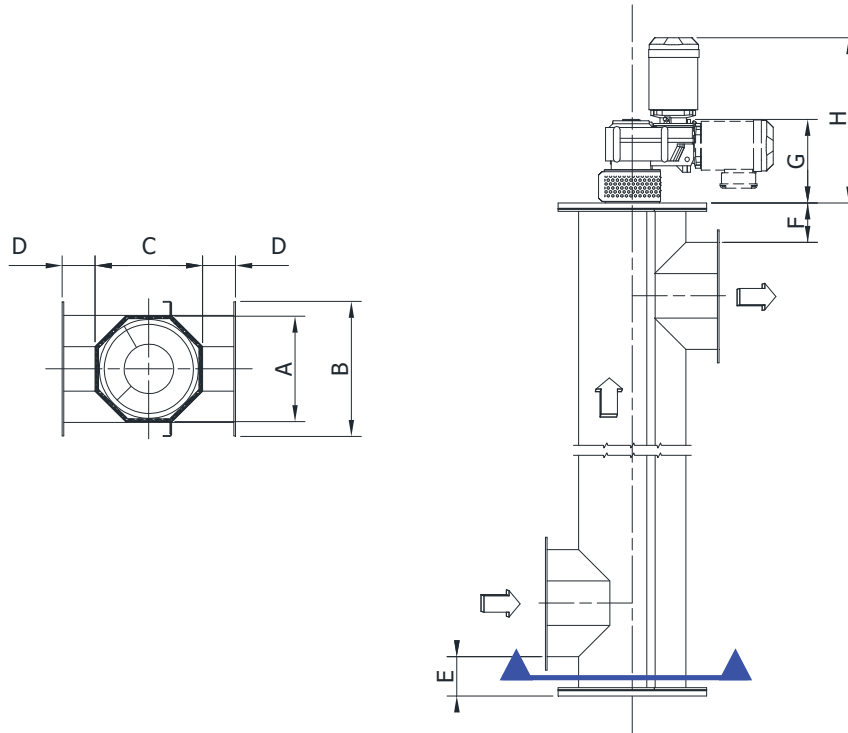

Trough Size	A (mm)	B (mm)	C (mm)	D (mm)	E (mm)	F (mm)	G (mm)	H (mm)
OK200	200	289	205	100	119	113	280	632
OK250	250	339	255	100	119	113	313	729
OK320	320	409	325	100	119	119	390	939
OK355	355	444	360	100	119	119	453	984
OK420	420	510	426	100	119	219	453	1159
OK500	500	590	506	100	119	219	453	1159
OK620	620	714	630	100	119	223	495	1332

Dimensions are for information only and not to be used for design. Please contact us for more details.

- Notes:
1. F dimension is subject to thickness of drive plate which varies with gearbox size
 2. Gearbox dimensions are representative only, based on common sizes, subject to final selections

DIMENSIONS SPIROLINE® (U-TROUGH)

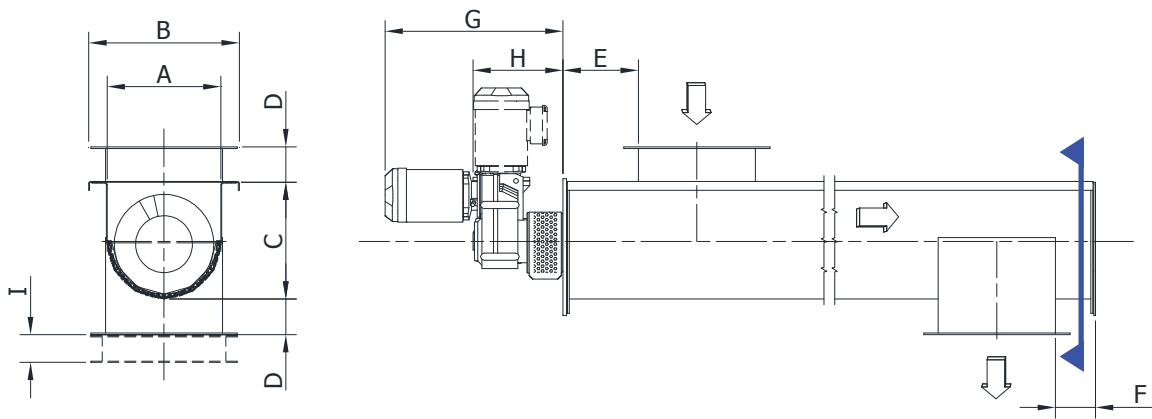

Trough Size	A (mm)	B (mm)	C (mm)	D (mm)	E (mm)	F (mm)	G (mm)	H (mm)	I (mm)
U200	200	304	205	100	213	107	632	280	78
U250	250	354	260	100	213	107	729	313	78
U320	320	424	329	100	219	107	939	390	78
U355	355	459	364	100	219	107	984	453	78
U420	420	545	419	100	219	107	1159	453	78
U500	500	625	497	100	219	107	1159	453	78
U620	620	750	609	100	223	107	1332	495	78

Dimensions are for information only and not to be used for design. Please contact us for more details.

- Notes:
1. F dimension is subject to thickness of drive plate which varies with gearbox size
 2. Gearbox dimensions are representative only, based on common sizes, subject to final selections

ABOUT SPIRAC

SPIRAC is all about screening, grit and sludge handling solutions. With SPIRAC solids handling solutions, you can have total confidence in a global leader.

SPIRAC enjoys more than 40 years of worldwide success and long-standing partnerships with customers, a prestigious status we didn't earn overnight. The SPIRAC network of engineers is on hand to collaborate with you right from the start of your project – wherever you are located. This way we understand your requirements enabling us to deliver the right solution for you. Professional Project Managers and Design Engineers will ensure that products and systems are manufactured, installed and maintained to the most exacting standards, in compliance with local specifications and best global practice.

And don't forget, full after sales support is part of SPIRAC's outstanding service.

WE SPECIALISE IN

SCREENINGS HANDLING

- ▶ Screens
- ▶ Screenings washing
- ▶ Dewatering & compaction
- ▶ Conveying
- ▶ Containment & transport

GRIT HANDLING

- ▶ Grit capture & separation
- ▶ Grit washing
- ▶ Conveying
- ▶ Containment & transport

SLUDGE HANDLING

- ▶ Conveying
- ▶ Storage (silos)
- ▶ Receival (bunkers & hoppers)
- ▶ Outloading (sliding-frames & live-bottoms)
- ▶ Containment & transport



AUSTRALIA

SPIRAC Pty Ltd

Western Australia (Perth)
+61 8 9434 0777

New South Wales (Sydney)
+61 2 8811 4100

Victoria (Melbourne)
+61 3 9717 1199

Queensland (Brisbane)
+61 7 3482 4230

info@spirac.com.au

NETHERLANDS

SPIRAC BV

Maarheeze
+31 (0) 495 430 203
info@spirac.nl

SWEDEN

SPIRAC AB

Limhamn
+46 40 36 22 00
info@spirac.se

UNITED KINGDOM

SPIRAC Limited

Banbury
+44 (1) 295 270 335
conveyors@spirac.co.uk

USA

SPIRAC (USA) Inc

Newnan GA
+1 770 632 9833
sales@spirac.com