

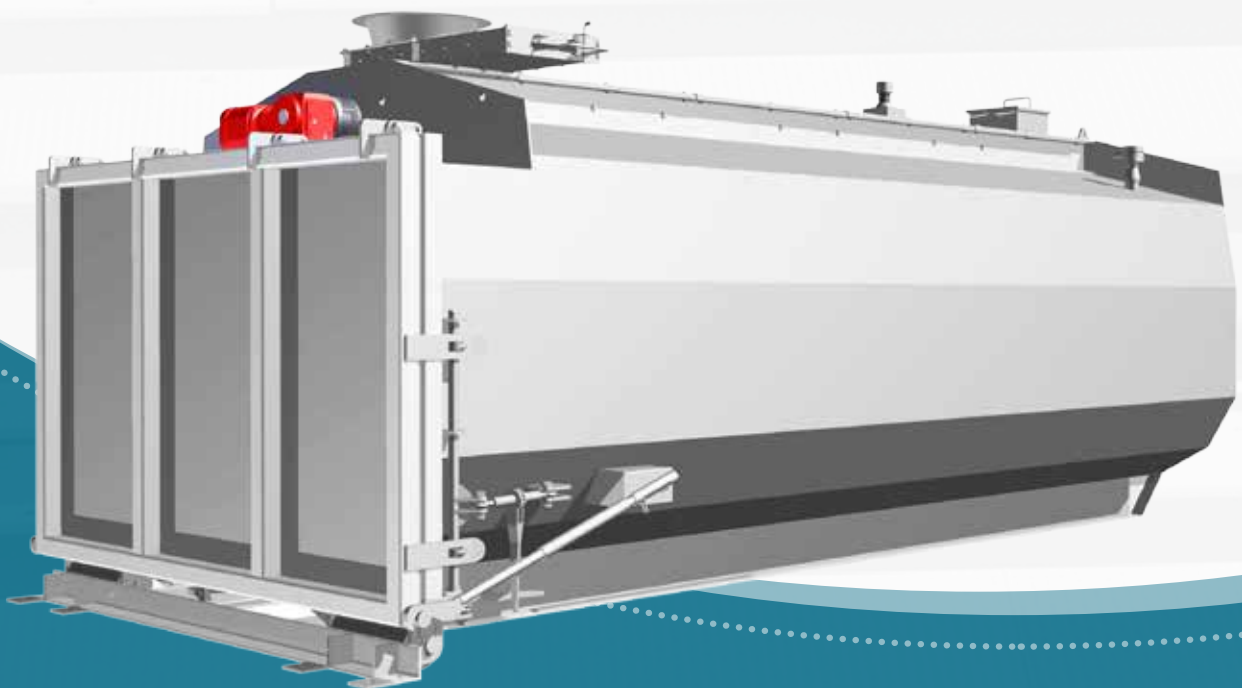

SPIRAC[®]

SPIROTAINER[®]

AUTOFILLING CONTAINMENT AND
ROAD TRANSPORT BIN SYSTEM



Combined with SPIRAC spiral conveyor systems, offensive waste products are transported, stored and removed from site with minimal operator intervention, virtually odour-, vermin- and insect-free.

A permanent onboard spiral conveyor and control system provide automated filling and level control while a robust door-sealing system ensures leakproof transport even with a large liquefied component. Standard truck lifting devices are incorporated into the design to facilitate transport. Once it has reached the destination, the SPIROTAINER® is emptied by simply tilting.



BENEFITS OF A SPIROTAINER®

- ▶ Suitable for screenings, grit (together or separate), or sludge.
- ▶ Deployable outdoors and indoors.
- ▶ Even load distribution along full length of bin.
- ▶ Heavy duty closure and locking mechanism with durable rubber gaskets for a positive seal.
- ▶ Quick-connect power and control sockets.
- ▶ Ultrasonic level-filling sensors to prevent overfilling.
- ▶ Robust construction and extreme paint finish suited to the rigors of contract hauling.
- ▶ SPIROTAINER® eliminates the need for a specialized screenings building.
- ▶ Extending system capacity is as easy as adding another SPIROTAINER®.

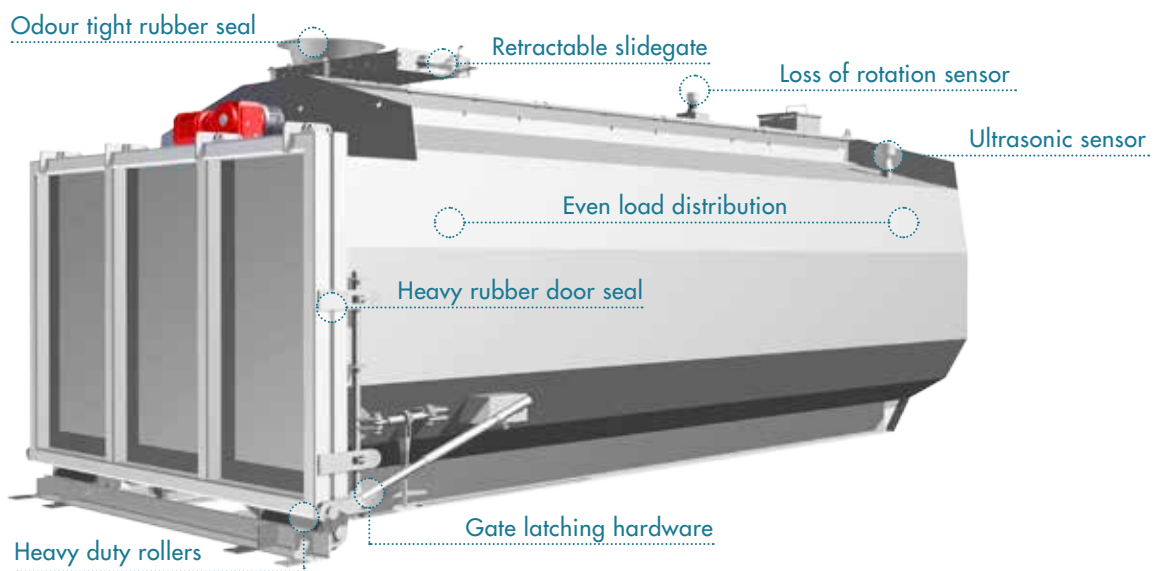

Storage capacity:

Nominal volumes are 13, 20 and 26yd³.

Filling Rate:

Up to 13yd³/hr.

Suitable for:

- ▶ Sewage screenings.
- ▶ Sewage sludge.
- ▶ Sand and grit.
- ▶ Food-processing by-products and waste streams.
- ▶ Industrial sludges, contaminants and general foul waste otherwise unsuitable for open top bins.

Available materials of construction:

Typically manufactured from high spec mild steel or, for extreme applications, stainless steel.

Corrosion Protection:

Many paint specifications are available to suit the requirements of different regions and climatic environments. These bins are generally located in corrosive, industrial environments and corrosion protection is critical to the long life-expectancy of these systems.

Optional Inlet Chutes:

Flexible chute or pneumatic retractable chute.

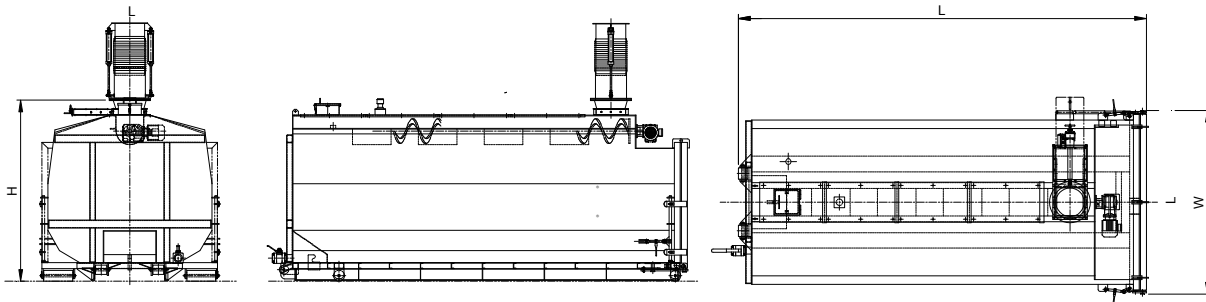

Model	Volume (yd ³)	Length L (in)	Width W (in)	Height H (in)	Weight (lb)
Americas					
STU-10	13	221"	94"	67"	6,000
STU-15	20	207"	93"	92"	7,700
STU-20	26	273"	93"	92"	8,800

Dimensions are for information only and not to be used for design. Please contact us for more details.

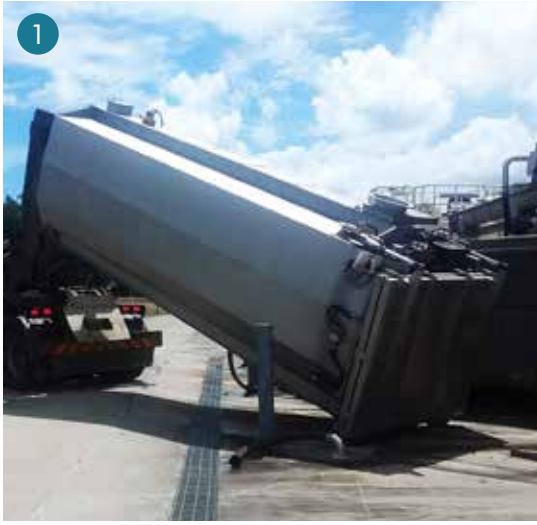

- 1. STAINLESS STEEL SPIROTAINER®
- 2. MULTI-BIN FILLINGS
- 3. AUTO CHANGEOVER SLIDEGATE WITH FLEX CHUTES
- 4. SLUDGE SYSTEM WITH WEIGH SCALES AND RETRACTABLE CHUTES



PLEASE CONTACT US FOR MORE INFORMATION

SPIRAC (USA) INC.

Postal Address:
75 Jackson Street Suite
300 Newnan Georgia 30263

Phone. +1 (770) 632 9833
Fax. +1 (770) 632 9838
E-mail. sales@spirac.com